

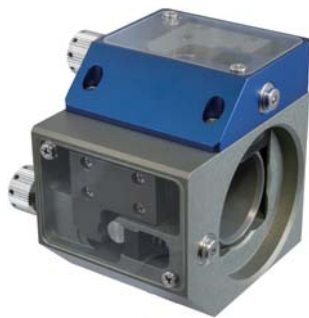

Fiber Aligner

FA1000S_FP

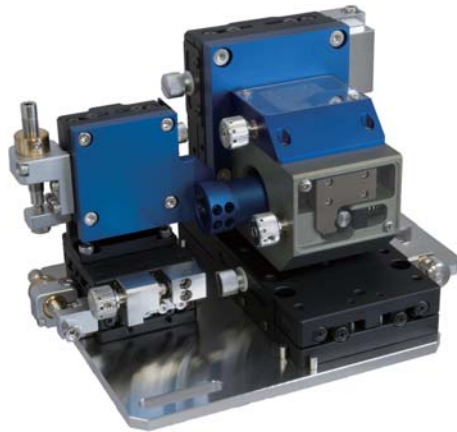

Sphere Gimbal Mechanism

FA1000S_theta



Internal Structure of Sphere Gimbal Mechanism

FA1000S_FP is a device to couple a Laser beam (TEM₀₀) which propagates in free space into an optical fiber (in LP₀₁ mode) through the aspheric lens, providing ultra-high coupling efficiency. FA1000S_FP has been developed by FMD with full cooperation of Professor Akira Furusawa of the University of Tokyo. 98% coupling efficiency was achieved by his lab, using the setup for evaluation outlined in Fig. 1 at the time of Jan, 2013.

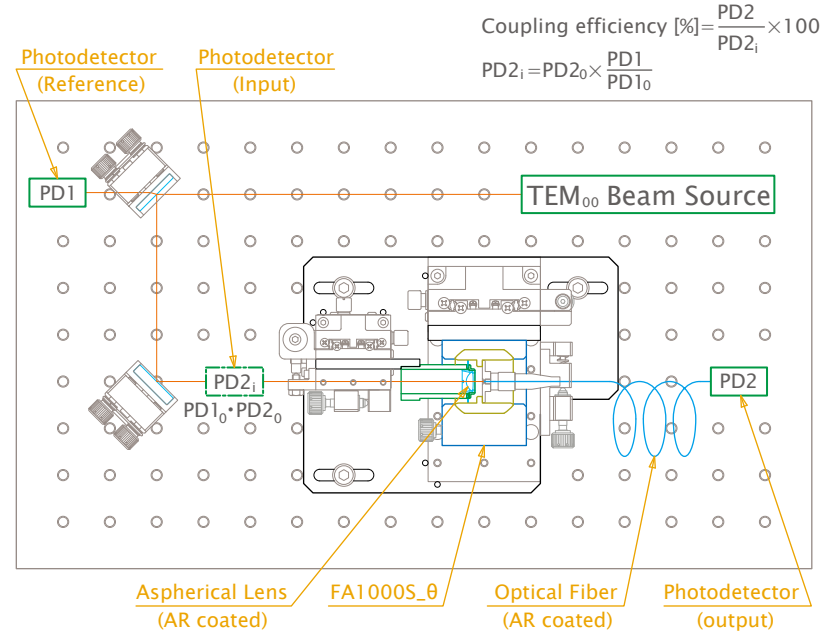

Fig.1 Outline of the Setup for Evaluation

98% coupling efficiency with optical fiber was achieved.

Sphere Gimbal Mechanism – FA1000S_theta

FA1000S_theta employs Sphere Gimbal Mechanism which is jointly patented by FMD and Professor Akira Furusawa of the University of Tokyo (Patent No. 5888775, JP). This mechanism enables the center of the end surface of an optical fiber to meet the intersection of two mutually perpendicular rotational axes θ_x and θ_y . Therefore, it makes hassle-free to adjust alignment which used to be time and labor consuming. After making adjustment using with ultra-precision adjusting screws with almost no backlash of which performance has been proved with MM1000S mirror mounts, unparalleled long-term stability can be retained by Soft Lock Mechanism (Patent application No. 2005-352867, JP).

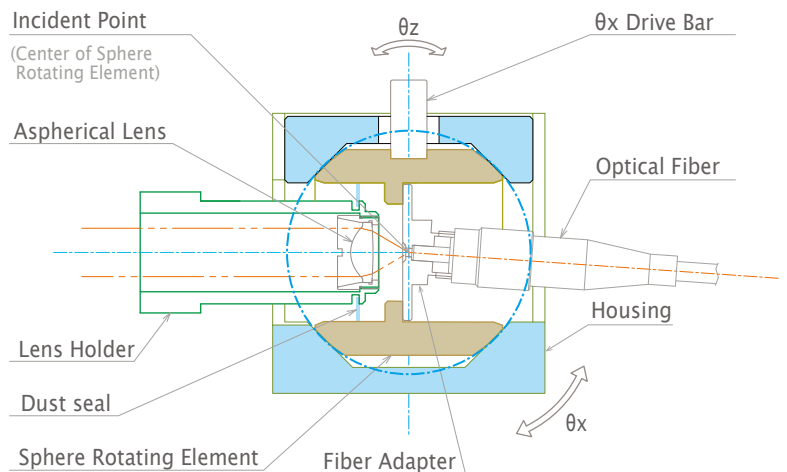

Fig.2 Sphere Gimbal Mechanism

Accessories



Special Wrench: SCR-ADJ

A specialized tool to make fine adjustment to the precision screws made by FMD



Special Wrench: SPW302_MOD

A specialized tool for attaching and removing the aspherical lens.



Special iris: ID15/M_Hi2Tm6

A specially designed tool for adjusting incident light into 2 inch high parallel light against an optical breadboard. Two pieces come with.

ID15/M_Hi2Ti1/4 is for an optical breadboard with inch screws(1/4"-20). Please specify when ordering.



Pinhole: PH016

A tool designed to guide an incident light into the center of the lens holder.

FA1000S_FP with FMD made fine pitch adjusters

FA1000S_FP equips FMD made ultra-precision adjusting screws. See the image on the left-hand side of the previous page. FA1000S_FP makes it possible to couple an optical fiber and a laser with ultra-high efficiency with relatively easy operation. The height of the optical axis is designed to 2 inches. When you need to change the height, you can adjust it by mounting the four posts under the base plate. The knob with a $\phi 12$ hole enables additional fine adjustments without difficulties, by using with a special wrench SCR-ADJ which comes with. SPW302_MOD is a wrench designed to attach/detach lens. A special Iris ID15/M_Hm25Tm6 to make fine adjustment of light axis comes with, which enables to adjust the height of a light axis and a pinhole (PH016) in 2 inches high to guide an incident light to the center of the lens.

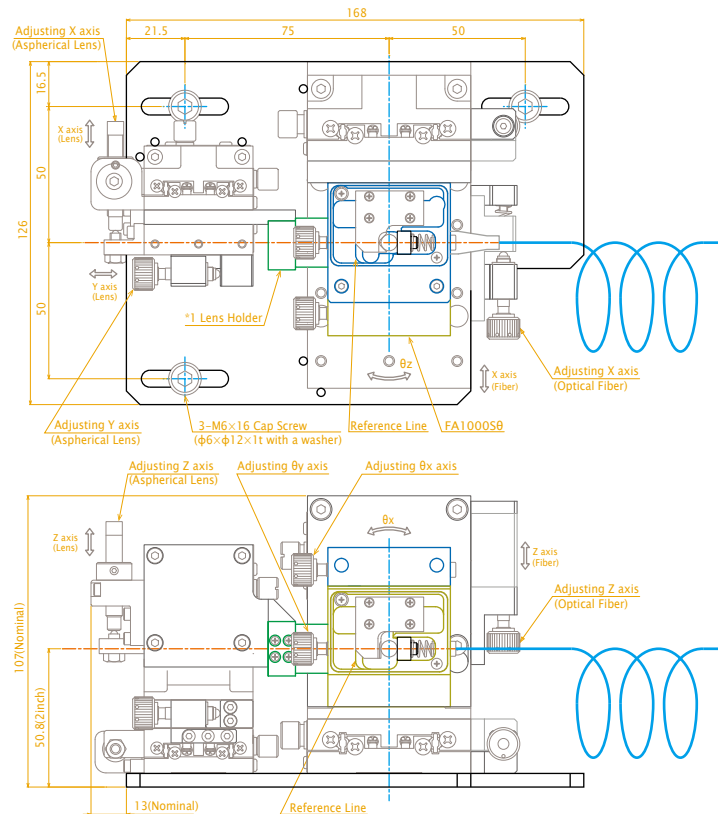

Fig. 3 FA1000S_FP Drawings

Dimensions	168 mm (W) x 126 mm (D) x 107 mm (H) (except knobs and fiber)
Weight	Approx. 3.6 kg
Mounting method	M6 x 12 CAP screw, $\phi 6 \times \phi 12 \times 1$ (t) washers
Fiber adapter	FC/APC or FC/PC
Lens	M12 x 0.5 male thread type aspheric lens (Contact us for details.)
Working distance	2.8 mm – 9.5 mm (between lens and fiber)
Tilt Range	$\pm 5^\circ$ (θ_x , θ_y)
Angular resolution	When the knob is turned 1 degrees
θ_x	0.0017° (18.9 μrad)
θ_y	0.0015° (21.4 μrad)

Remarks

FMD made ultra-fine adjusting screws with 0.15mm pitch are used. The screws have been used in FMD's ultra-stable mirror mount MM1000S to prove almost no backlash and hysteresis for long time.

FA1000S_DM with a micrometer for less fine adjusting than FA1000S_FP is available upon your request. Contact us for details.