

Fiber Optical Strain Relief Boots and Dust Caps

Fiber optical strain relief boot is to be used for reducing the strain and tension at curve transition location of fiber optical components and devices, mostly used in connector or fiber terminator. Fiber optical dust cap is used to prevent the fiber connector from dust and other contaminations.

Features of fiber optical strain relief and dust cap:

- Many different size strain relief boot and dust cap for 3mm and 900um connectors
- Designed to be used for different size crimp sleeves
- Different color of boot and dust cap
- Standard products and customer made products
- Low cost products
- Technical support is available

Applications for our strain relief boot and dust cap:

- Fiber optical telecommunication
- Fiber optical component and device
- Fiber optical instruments
- Biomedical and other industry applications

Fiber boot and dust cap photos and drawings:

[Standard precision is ± 0.2 mm]

OEBOOT-5, 8, and 7



Diagrams:

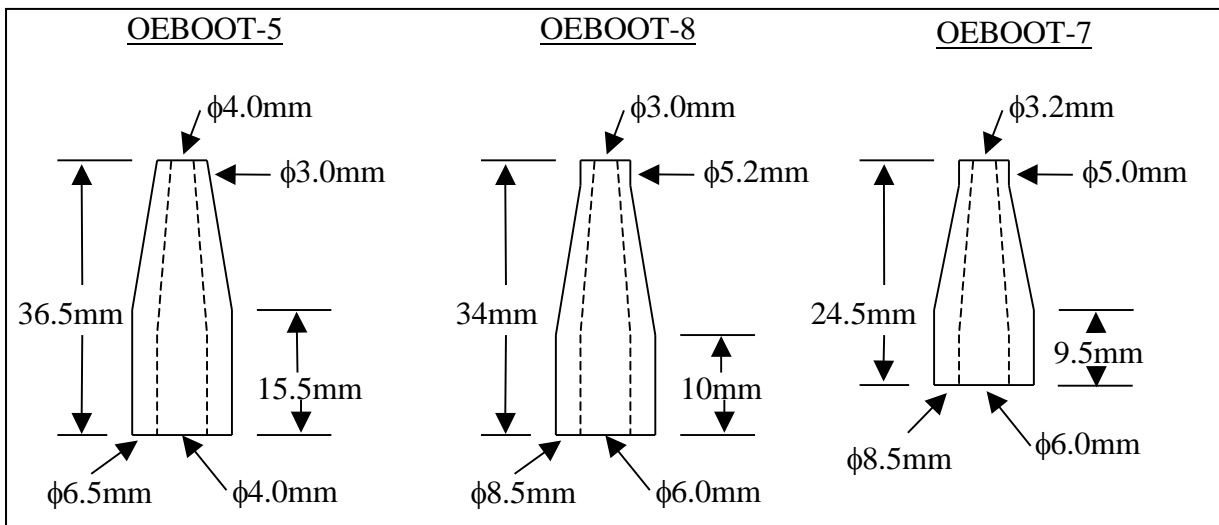

OEBOOT-3, 9 and 10

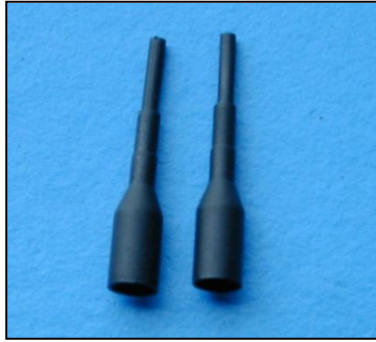

Diagrams:

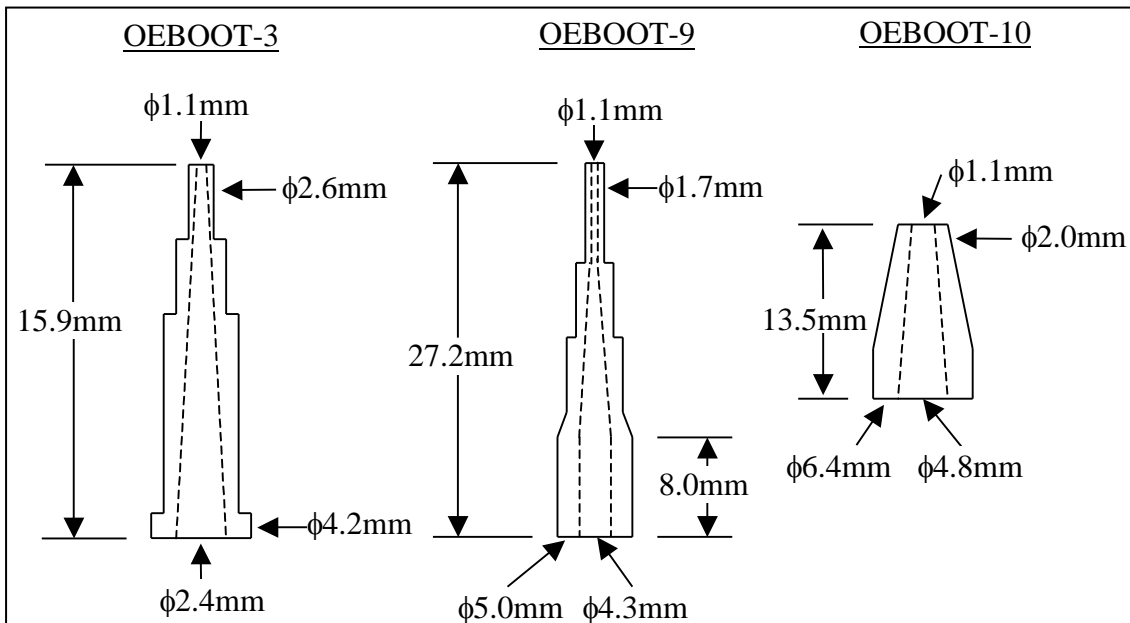

OEBOOT-4 and 1

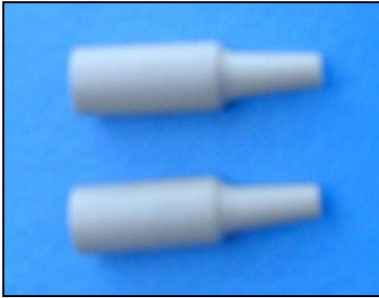

Diagrams:

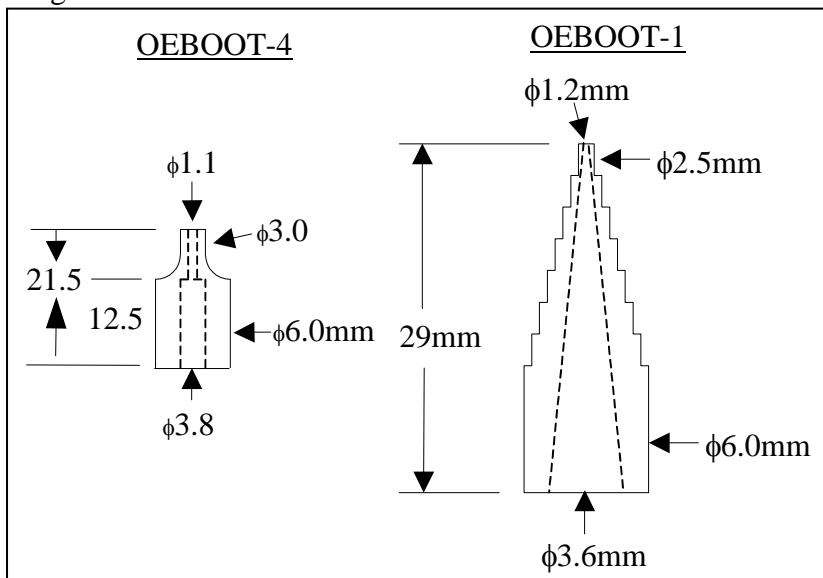

OEBOOT-11, 14 and 15



Diagrams:

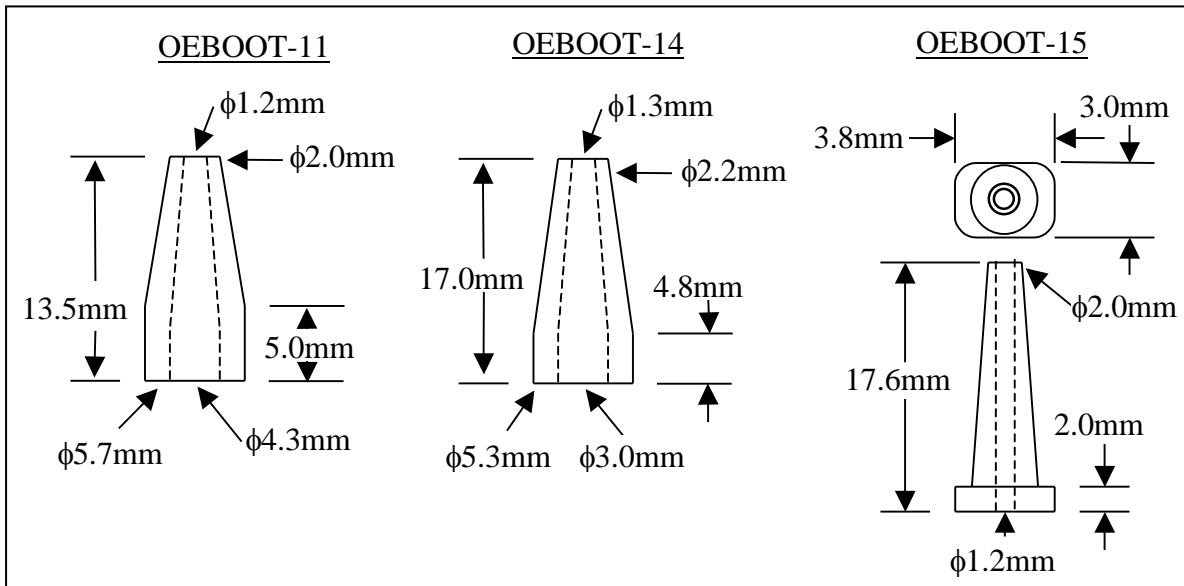

OEBOOT-16

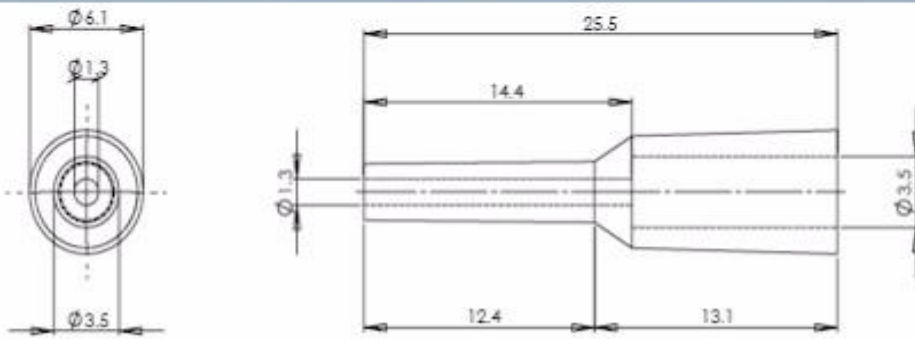
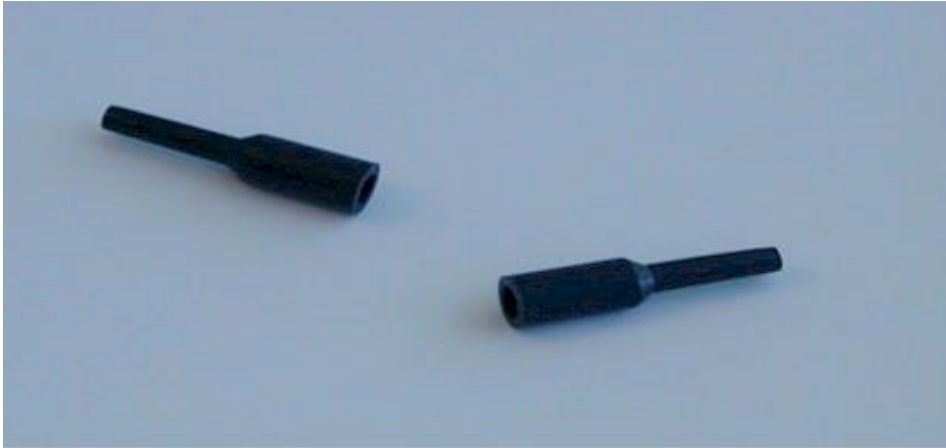

OEBOOT-28

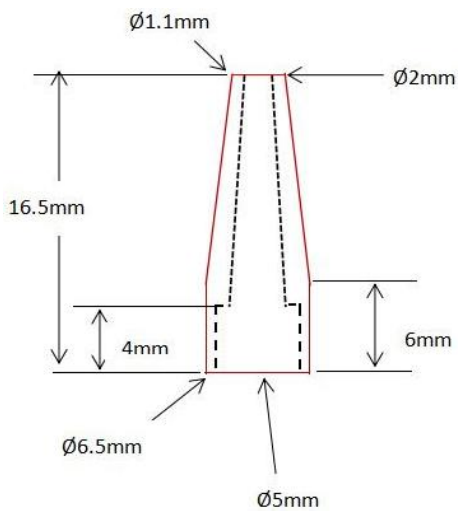

OEBOOT-29

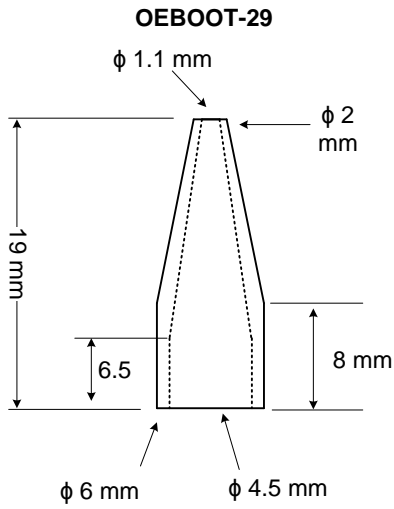

OEBOOT-30

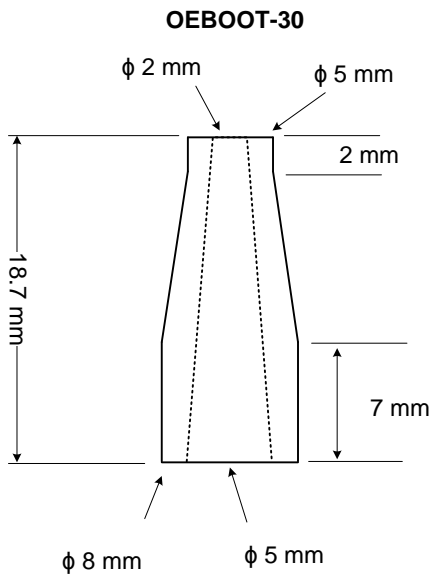

OEBOOT-31

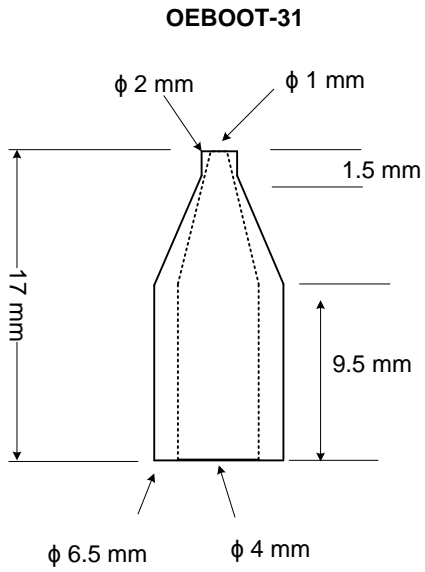

OEBOOT-32

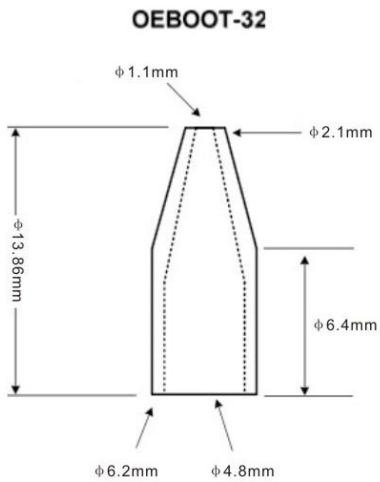

OEBOOT-33

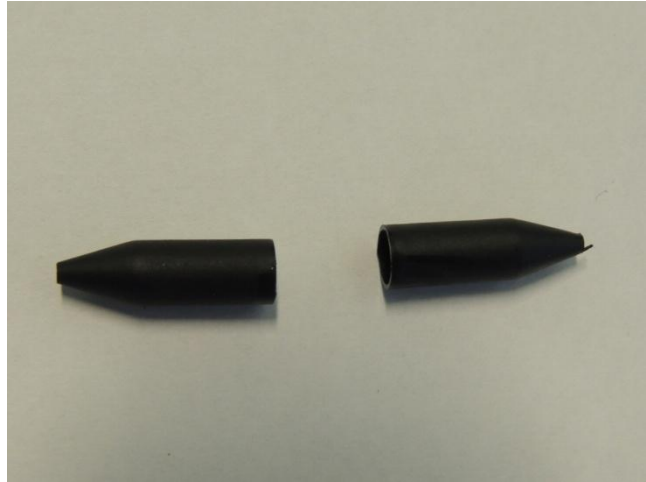
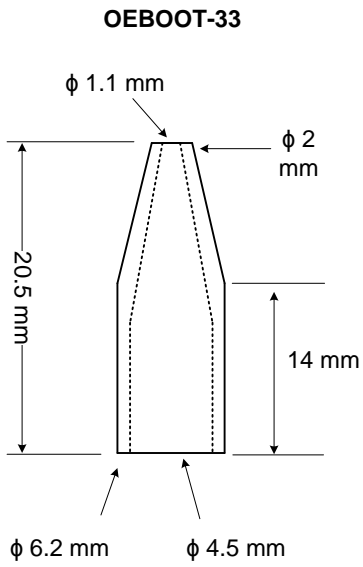

OEBOOT-34

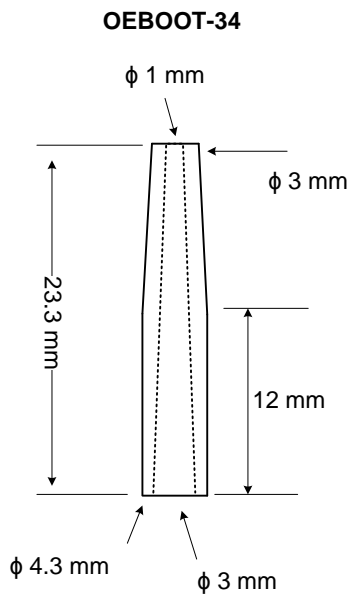

OEBOOT-35

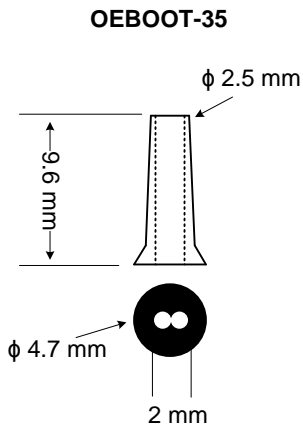

OEBOOT-36

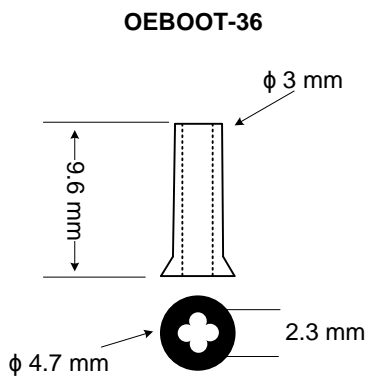

OEBOOT-37

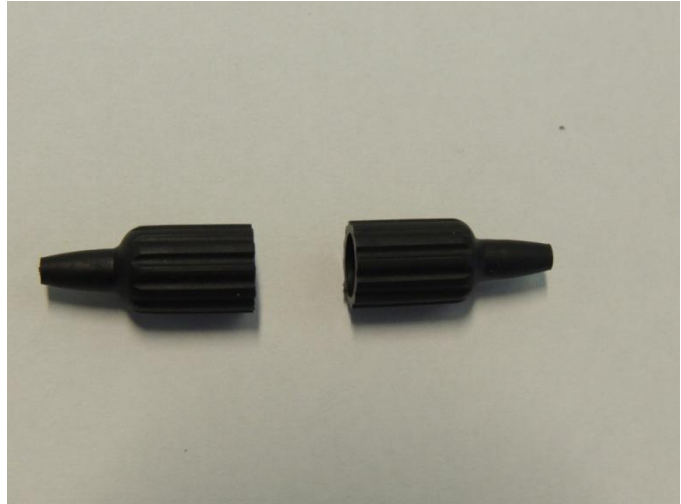
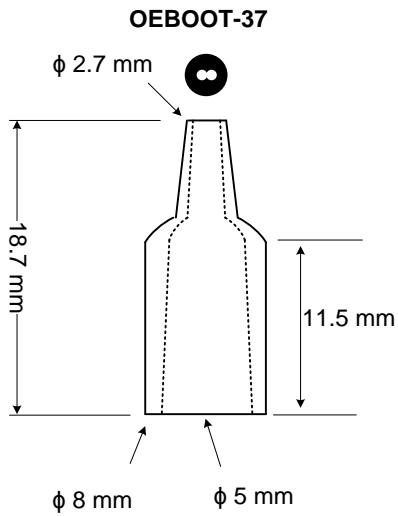

Dust caps:

OECAP-17, 21, 4

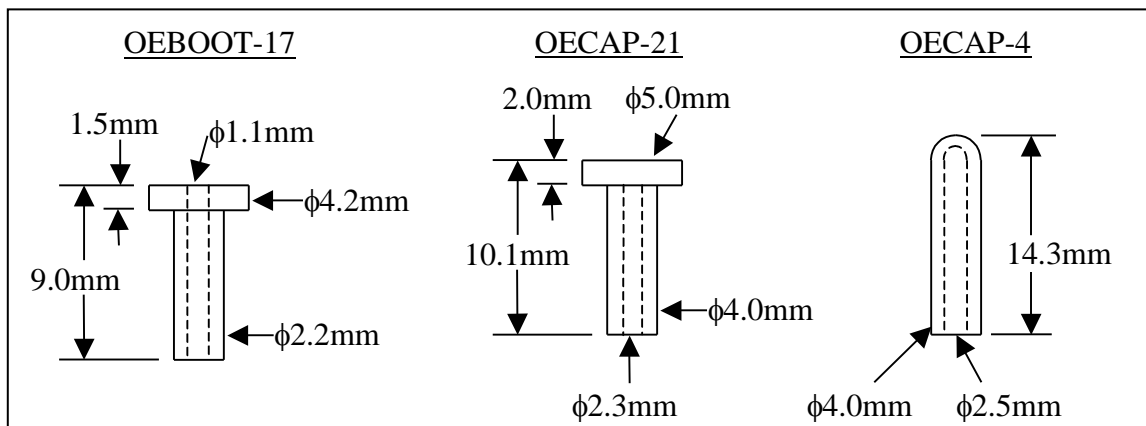

OE CAP-22, 23

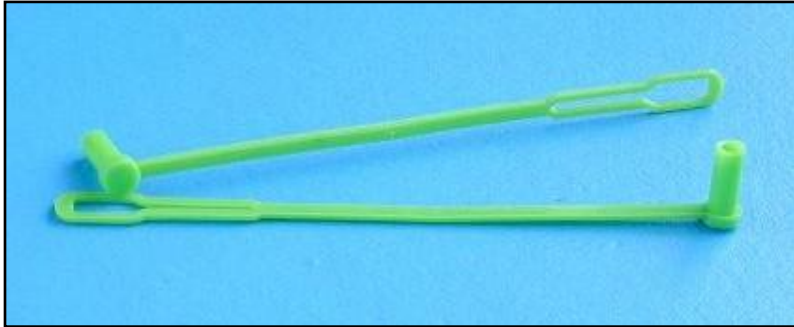

Diagrams:

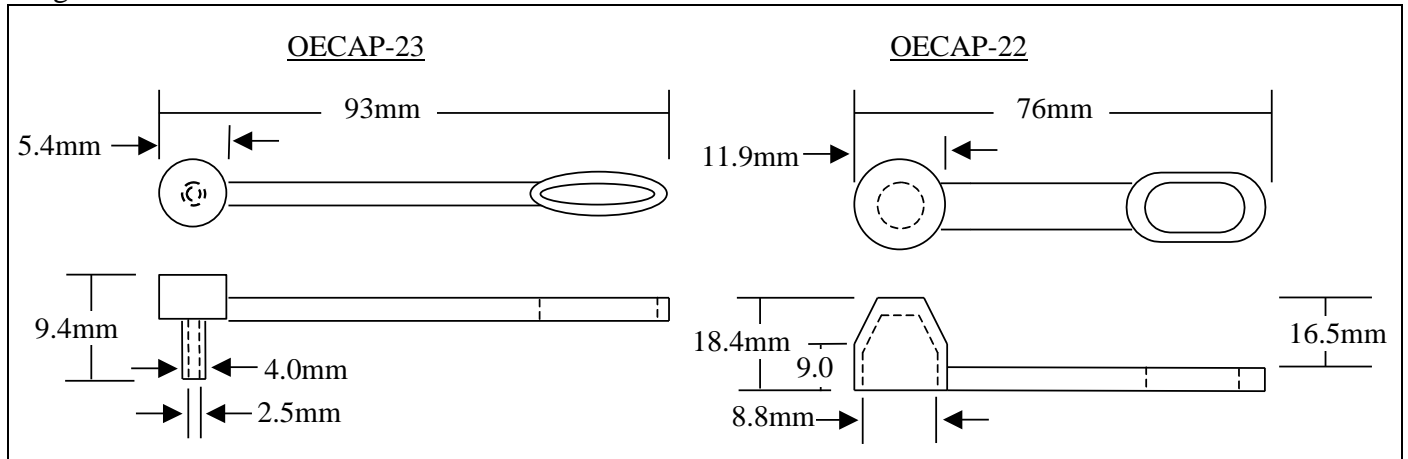

Note: All specifications are subject to change without notice