

Diode Pumped Picosecond Passively Q-Switched Lasers

MPL2310

FEATURES

- > More than **2 mJ** pulse energy at **1064 nm**
- > Short pulse duration **< 500 ps**
- > **1 – 100 Hz** repetition rate
- > Ultra-compact
- > Passively Q-switched
- > Average power **200 mW**
- > High peak power **> 4 MW**
- > Guaranteed **> 3 Gshot** lifetime
- > Other wavelengths (e.g. 532 nm, 355 nm, 266 nm) are available

APPLICATIONS

- > Laser-induced breakdown spectroscopy (LIBS)
- > Time resolved fluorescence measurements
- > DNA analysis
- > Pollution monitoring
- > Remote sensing
- > Supercontinuum generation
- > Ignition of gas mixtures

MPL2310 series DPSS passively Q-switched sub-picosecond lasers deliver high peak powers **> 5 MW** at **100 Hz** repetition rate. Short laser cavity is fixed on thermo-stabilized and controlled baseplate which gives extremely stable output parameters performance. Small footprint is welcome point for integration into OEM lasers. Sub-nanosecond pulse duration of **< 350 ps**, high pulse energy more than **2 mJ**, variable repetition rate from 1 Hz to 100 Hz covers many applications like pollution monitoring, DNA analysis, supercontinuum generation and many others.

Due to short pulse duration and high pulse energy laser delivers high peak power which is up to 5 MW. Optional conversion to green (532 nm) and ultraviolet (355 nm, 266 nm) is also available.



Specifications ¹⁾

MODEL	MPL2310 / MPL2510	MPL1310 / MPL1510
Pulse energy		
at 1064 nm	2 mJ	1 mJ
at 532 nm	1 mJ	0.5 mJ
at 355 nm	0.5 mJ	0.25 mJ
at 266 nm	0.25 mJ	0.15 mJ
Typical pulse duration	<350 ps/ <500 ps ²⁾	
Pulse to pulse energy stability (RMS)		
at 1064 nm	< 1.0 % ³⁾	
at 532 nm	< 2.0 % ³⁾	
at 355 nm	< 3.0 % ³⁾	
at 266 nm	< 4.0 % ³⁾	
Power drift	± 3.0 % ⁴⁾	
Pulse repetition rate ⁵⁾	1 – 100 Hz	
Beam profile	close to Gaussian	
Beam divergence ⁶⁾	< 6 mrad	
Polarization	linear, horizontal at 1064 nm	
Spectral linewidth	SLM	
Beam pointing stability ⁷⁾	< 10 µrad	
Typical beam diameter ⁸⁾	1.5 mm	
Optical jitter	~ 2 µs RMS ⁹⁾	

DIMENSIONS

Laser head (W×L×H)	125 × 295 × 76 mm (with harmonics)
	99 × 174 × 45.5 mm (OEM version)
Controller unit (W×L×H)	257 × 271 × 153 mm
	75 × 200 × 70 mm (OEM version)

OPERATING REQUIREMENTS

Cooling requirements	air cooled	
Ambient temperature	15 – 30 °C	
Relative humidity	10 – 80 % (non-condensing)	
Mains voltage	100 – 230 VAC, single phase, 50 – 60 Hz ¹⁰⁾	
Power consumption	< 20 W	< 10 W

- ¹⁾ Due to continuous improvements all specifications are subject to change. Unless stated otherwise all specifications are measured at 1064 nm.
- ²⁾ FWHM level at 1064 nm.
- ³⁾ Averaged from 60 seconds time interval in 5 series.
- ⁴⁾ Over 8-hour period after max 5 minutes of warm-up when ambient temperature variation is less than ±2 °C.
- ⁵⁾ Factory-set pulse repetition rate is fixed at 100 Hz repetition rate. Higher repetition rates are available, please inquire for more details.
- ⁶⁾ Full angle measured at the 1/e² level. Lower beam divergence is available upon request, please inquire for more details.
- ⁷⁾ RMS value measured from 1000 shots.
- ⁸⁾ Beam diameter is measured 20 cm from laser output at the 1/e² level.
- ⁹⁾ In respect to Q-switch triggering rising edge pulse.
- ¹⁰⁾ Laser can be powered from appropriate 12 VDC power source. Inquire for details.

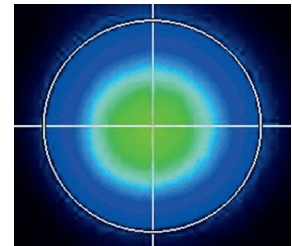

Typical beam intensity profile (20 cm from laser output) of MPL2310 series lasers

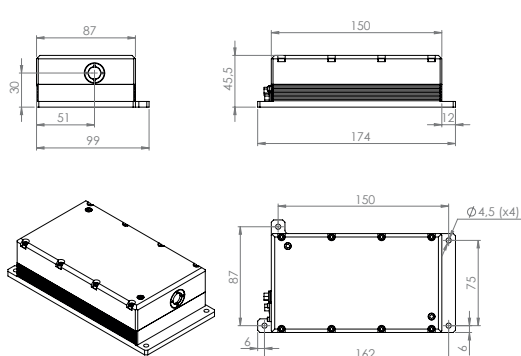

MPL2310 series laser head dimensions OEM version (in mm)

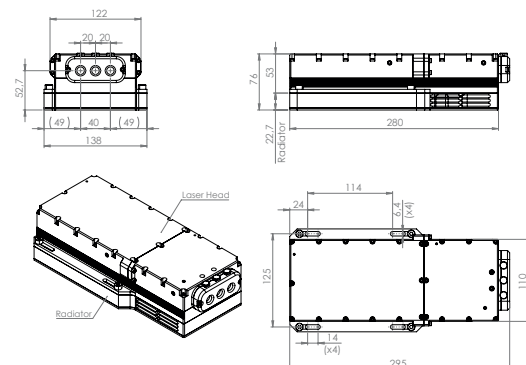

MPL2310 series laser head dimensions (in mm)